

RESEARCH INTO EXTENSOMETRIC FLOWMETER OF AIR SUCKED IN BY PISTON ENGINE

Jerzy Mirkowski

*Institute of Internal Combustion Engines and Control Engineering
Czestochowa University of Technology
42-200 Czestochowa, ul. Armii Krajowej 21
tel.: +48 34 32-50-507*

Marcin Sosnowski

*Institute of Internal Combustion Engines and Control Engineering
Czestochowa University of Technology
42-200 Czestochowa, ul. Armii Krajowej 21
tel.: +48 34 32-50-543*

Abstract

Researches into extensometric flowmeter prototype as alternative device used during measurements of air sucked in by piston engine are presented in the paper. The principle of extensometry is based on the variation in resistance of light-gauge metal wire exposed to linear strain. The advantage of designed and made extensometric flowmeter prototype is the unsophisticated design and lack of moving parts, which influences the reliability of the device. The measurements were conducted in static conditions for three different angles of incidence on test stand equipped with Roots blower powered by electric motor. The test stand was capable to generate the flow rate of 0,075 m³/s to 0,275 m³/s.

1. Introduction

The measurement of amount of air delivered to the cylinder is one of the most important piston engine measurements because it provides the researcher with information concerning engine flow characteristics such as fill rate and lets the estimation of combustion conditions to be done on the basis of mixture composition. Unfortunately it is also one of the most difficult piston engine measurements because of the necessity of eliminating the influence of pulsation connected with engine work and ensuring the least possible pressure drop caused by the flowmeter.

2. The extensometry

The principle of extensometry is based on the variation in resistance of light-gauge metal wire exposed to linear strain. Within the limits of elasticity the resistance variation is proportional to the linear strain. In order to obtain certain values of strain an analytical dependency between the relative strain and the variation of the extensometer's resistance must be determined with assumption of equality of extensometer unit strain and the structural component on which the extensometer is mounted.

The dependency (1) is the fundamental equation in the field of extensometry and joins the main mechanical and electrical parameters of extensometer work.

$$\frac{\Delta R}{R} = K \cdot \varepsilon , \quad (1)$$

where: ΔR – increment of extensometer resistance,
 R – extensometer resistance,
 K – extensometer constant,
 ε – relative strain.

As it can be noticed from the above mentioned dependency the relative increment of resistance $\Delta R/R$ is increasing with the increase of the measured strain and the increase of the extensometer constant K . The strain is yet limited by the strength of used material and linearity of it's characteristic. The advantages of extensometry in comparison with other measurement techniques caused it to be widely used during mechanical quantities measurement because the measure of mechanical quantity with the use of extensometry is reduced to the measure of strain caused by the quantity. The adequate design of the processing unit that converts the strain of the measuring element to the measured quantity is essential. The converters made with the use of this technique are very simple, not expensive and in many cases more precise than converters based on other measurement techniques.

3. The extensometric sensor of flow velocity and flow rate

The measurement of flow rate with the use of extensometric flowmeter is based on the use of the influence of aerodynamic force on the shape mounted angularly to the direction of the flow. The kinetic pressure of the flow initiates the force, which bends the elastic shape with mounted extensometers. The bending force is proportional to the flow velocity at stable angle of incidence, which is the angle between the plain of the elastic shape and the direction of the flow. At constant flow velocity the bending force is proportional to the angle of incidence. Therefore the device permits fast and easy change of measuring range by changing the value of the angle of incidence.

The flow rate of air sucked in by piston engine of FSO Polonez vehicle and the character of the flow were preliminarily determined in order to estimate the dimensions of the elastic shape. The flow rate was calculated on the basis of equation (2).

The Reynolds number was calculated using equation (3) in order to determine the character of the flow.

$$Q_v = \frac{V_{ss}}{4 \cdot 10^6 \cdot 60} \cdot n \cdot \eta_v = \frac{1598}{4 \cdot 10^6 \cdot 60} \cdot 5200 \cdot 0.85 \approx 0.03 \frac{m^3}{s}, \quad (2)$$

where: V_{ss} – swept volume of the engine [cm^3],
 n – rotational speed [rpm],
 η_v – fill rate.

$$Re = \frac{V \cdot D}{\nu} = \frac{70 \cdot 0.075}{1.088 \cdot 10^{-5}} \approx 480\,000, \quad (3)$$

where: V – maximal velocity in the inlet duct [m/s],
 D – diameter of the inlet duct [m],
 ν – coefficient of kinematic viscosity [m^2/s].

The above calculations show the turbulent character of the flow.

The aerodynamic force, which bends the elastic element of dimensions equal $b=25$ mm (width), $l=50$ mm (length) and $h=0.4$ mm (thickness) is expressed by equation (4).

$$P_x = C_x \cdot \frac{\rho \cdot V^2}{2} \cdot S = 1.16 \cdot \frac{1.185 \cdot 70^2}{2} \cdot 0.00125 \approx 4.21 \text{ N}, \quad (4)$$

where: C_x – drag coefficient,
 ρ – density of the medium [kg/m³],
 S – the elastic shape area [m²].

The value of moment in the place of mounting was calculated on the basis of equation (5)

$$M = P_x \cdot l = 4.21 \cdot 0.05 = 0.2105 [Nm], \quad (5)$$

where: l – length of the elastic shape [m].

The strain of the elastic shape caused by the aerodynamic force P_x is given by equation (6).

$$\varepsilon = \frac{6 \cdot P_x \cdot l}{E \cdot b \cdot h^2} = \frac{6 \cdot 4.21 \cdot 0.05}{2.19 \cdot 10^{11} \cdot 0.025 \cdot 0.0004^2} = 1.442 \cdot 10^{-3}, \quad (6)$$

where: E – Young's module [Pa],
 b, h – width and thickness of the elastic shape [m].

Equation (7) bounds the electric output signal with the measured flow velocity and with the dimensions of the elastic shape of the flowmeter.

$$\frac{\Delta U}{U} = \frac{3 \cdot \rho \cdot C_x \cdot l^2 \cdot V^2}{E \cdot h^2} = \frac{3 \cdot 1.185 \cdot 1.16 \cdot 0.05^2 \cdot 70^2}{2.19 \cdot 10^{11} \cdot 0.0004^2} = 1.442 \frac{mV}{V}. \quad (7)$$

4. The design of the prototype

The main elements of the flowmeter are the measuring unit and the processing unit, which consists of voltmeter, amplifier and power supply joined with the measuring unit by connecting wires with 9-pin plug.

4.1. The measuring unit

The measuring unit of the flowmeter (Fig. 1, Fig. 2) consists of elastic shape placed in the flow duct (Fig. 3). The elastic shape is mounted to the bracket with the use of two M3 screws and the connecting wires pass through the centre of the mounting bracket. The screws are protected against twisting off with „LOCTITE 243”. Two TENMEX TF2/350 extensometers are stuck on the elastic shape with the use of cyanacrylate glue. One of them is stuck on along vertical axis (measuring extensometer) and the other one is stuck along horizontal axis (compensating extensometer). The mounting bracket is cylinder shaped with a flange, which lets the elastic shape to be turned in horizontal plane in order to set the desired value of angle of incidence. The casing of the measuring unit consists of two plexiglass elements placed on metal channel bar and joined with four M5 screws. Two rubber flanges with clamping rings are used to mount the unit on the test stand. The processing unit (Fig. 5) consists of a voltmeter, amplifier and power supply integrated in single casing on which there are power switch, voltmeter switch, amplifier resetting button, display and balancing potentiometer. The extensometers of the measuring unit are connected with resistors to form Wheatstone bridge equipped with *Helipot* potentiometer and powered by voltage of 5V, which was set to such value to match up with the maximal value of extensometer current (40mA). The offset voltage is amplified in the differential amplifier designed on the basis of *UA 7741* chip.

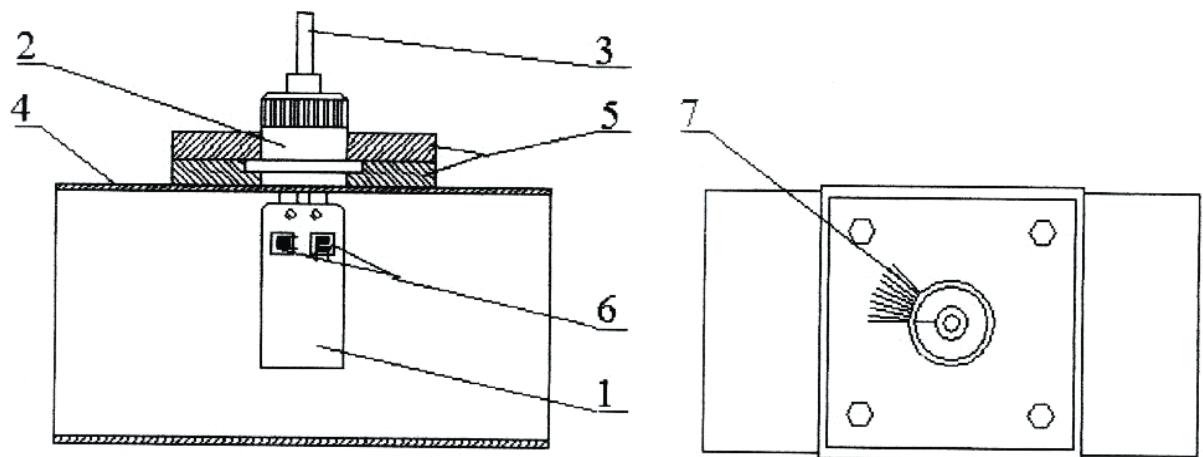

Fig. 1. The design of the measuring unit; 1 – elastic shape; 2 – mounting bracket of the elastic shape; 3 – connecting wires; 4 – flow duct; 5 – casing of the mounting bracket; 6 – extensometers; 7 – angle of incidence scale

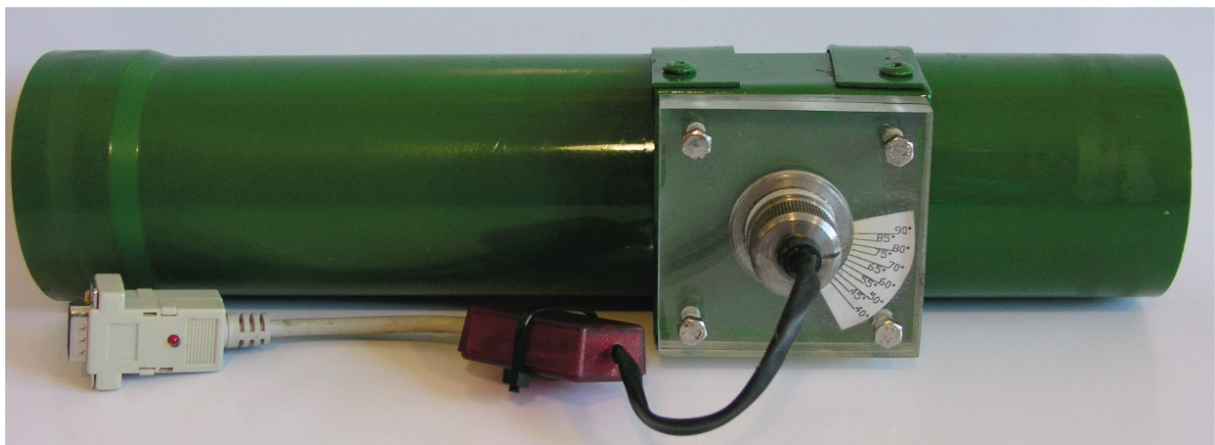

Fig. 2. The measuring unit of the extensometric flowmeter

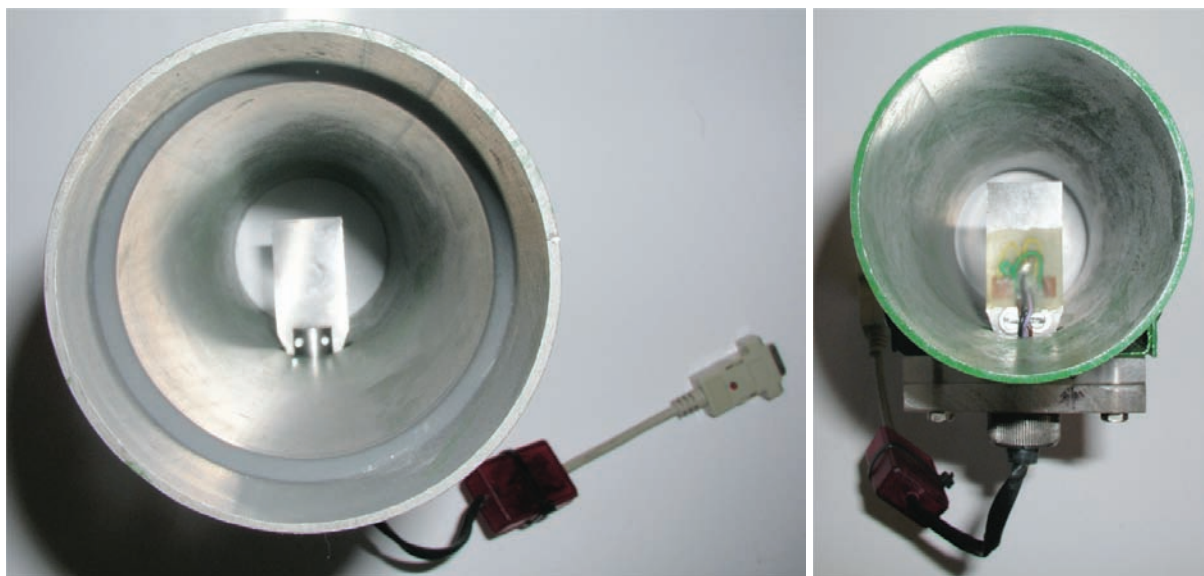

Fig. 3. The view of both sides of the elastic shape with extensometers in the flow duct

4.2. The processing unit



Fig. 4. The processing unit

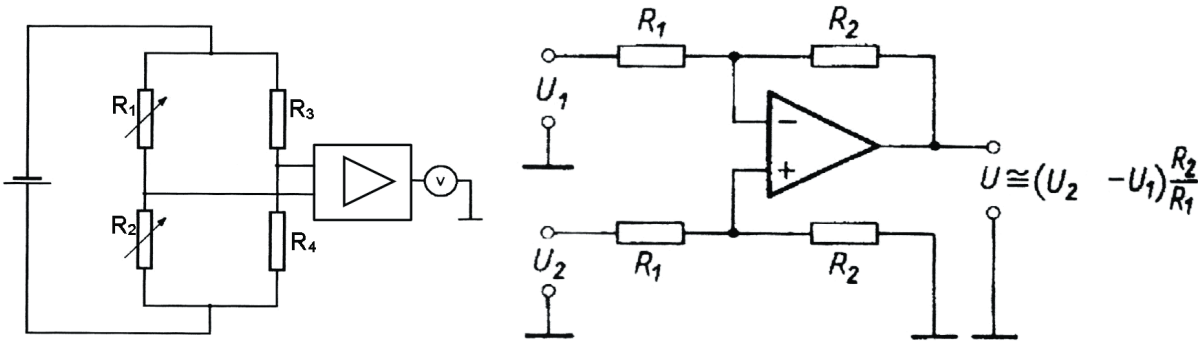

Fig. 5. The diagram of the processing unit (on the left) and differential amplifier (on the right)

5. Research of the flowmeter prototype

The researches of the flowmeter prototype were conducted on the flowmeter test stand in the Institute of Internal Combustion Engines and Control Engineering of the Czestochowa University of Technology. Roots blower powered by electric motor produces the flow on the test stand. The blower is equipped with throttling valve used to adjust the flow rate. The measurements were conducted for three different angles of incidence equal 45°, 60° and 80°. The characteristic curves of the flowmeter prototype for these angles are depicted in Fig. 6.

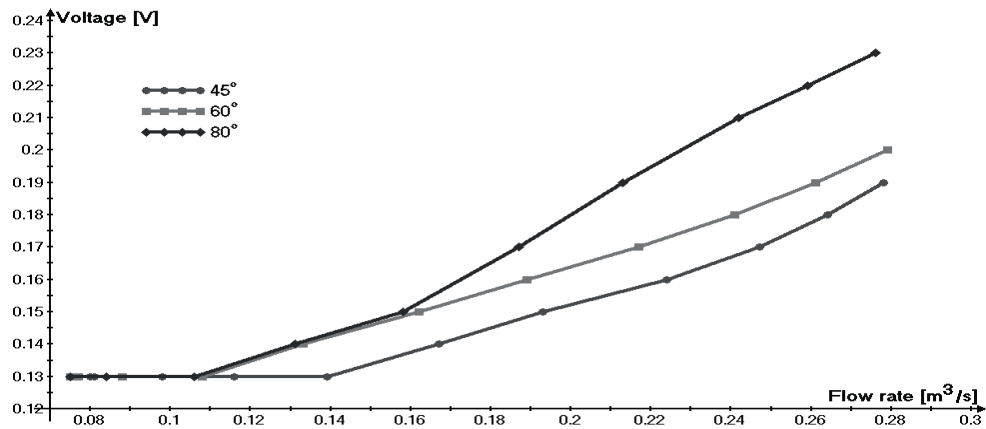

Fig. 6. The characteristic curves of the flowmeter prototype for three different angles of incidence

6. Conclusions

The advantage of designed and made extensometric flowmeter prototype is the unsophisticated design and lack of moving parts, which influences the reliability of the device. The prototype was made of cheap and easy to get materials, which is very important in the case of mass production of the extensometric flowmeter. The test stand was capable to generate flow rate of $0.075 \text{ m}^3/\text{s}$ to $0.275 \text{ m}^3/\text{s}$ and the flowmeter was tested in these conditions. The undergone researches showed the increase of voltage signal along with the increase of angle of incidence. Moreover they revealed the presence of the dead zone of the flowmeter in flow rate range of $0.075 \text{ m}^3/\text{s}$ to $0.1 \text{ m}^3/\text{s}$.

Literatura

- [1] Wada I., Electromagnetic flowmeters and method of producing electromagnetic flowmeters with slits to reduce eddy currents; Flow Measurement and Instrumentation Volume: 8, Issue: 1, March, 1997, pp. 51.
- [2] Kobayashi T., Torumaru T., Capacitance type electromagnetic flowmeter; Flow Measurement and Instrumentation Volume: 6, Issue: 3, 1995, pp. 245.
- [3] Lew Hyok, Lew Yon, Lew Hyon, Method for obtaining zero flowmeter reading for zero flow, Flow Measurement and Instrumentation Volume: 6, Issue: 3, 1995, pp. 245;
- [4] Spindel K., Funnel inlet and funnel outlet for ultrasonic gas meters; Flow Measurement and Instrumentation Volume: 8, Issue: 1, March, 1997, pp. 51.
- [5] Kimoto Junya, Aoyama Akira, Ito Shoji, Effects of Oscillating Flows on Measurement of Air Flow Rate - In the Case of Vortex Flowmeter; JSAE Review Volume: 17, Issue: 1, January, 1996, pp. 98.
- [6] Saikalis G., Smart mass gas flow sensor; Flow Measurement and Instrumentation Volume: 8, Issue: 1, March, 1997, pp. 51.
- [7] Berrebi J., van Deventer J., Delsing, J.; Reducing the flow measurement error caused by pulsations in flows; Flow Measurement and Instrumentation Volume: 15, Issue: 5-6, October - December, 2004, pp. 311-315.
- [8] Fu Zenxiang, Shi Jize, Wu Shichun, A theoretical study of the optimum linearity conditions of the structure of an axial extensometer; Journal of Materials Processing Technology Volume: 69, Issue: 1-3, September, 1997, pp. 152-154.